

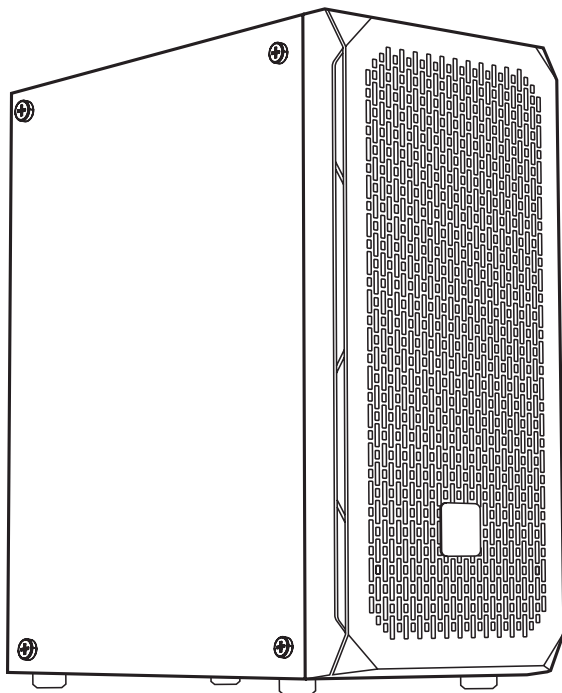

GAMING COMPUTER CASE

GABINETE GAMING

CAJA PC GAMING



INSTRUCTION MANUAL

GCM-ASGX1-01

Warranty and product information

Garantía e información del producto

These terms shall be governed and construed under laws of the jurisdiction in which the product was purchased, if any term here is held to be invalid or unenforceable, the such term (in so far as it is invalid or unenforceable) shall be given no effect and deemed to be excluded without invalidating an of the remaining terms. Getttech reserves the right to amend any term at any time without notice.

Estos términos se registrarán e interpretarán de acuerdo con las leyes de la jurisdicción en la que se compró el producto, si alguno de los términos en este documento se considera inválido o inaplicable, dicho término (en la medida en que sea inválido o inaplicable) no tendrá efecto y se considerará excluido sin invalidar ninguno de los términos restantes. Getttech se reserva el derecho de modificar cualquier término en cualquier momento sin previo aviso.



Computer Assembly Steps

Pasos de ensamblaje de la computadora

1) Remove side panel

1) Retire el panel lateral

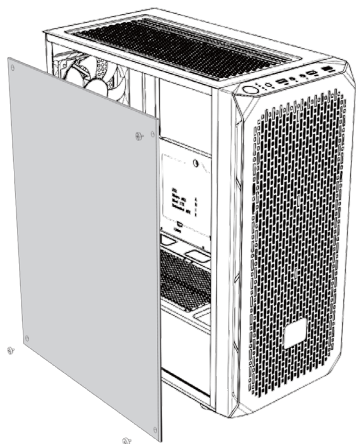

3) VGA / PCI-Express card installation

3) Instalación de tarjeta VGA / PCI-Express

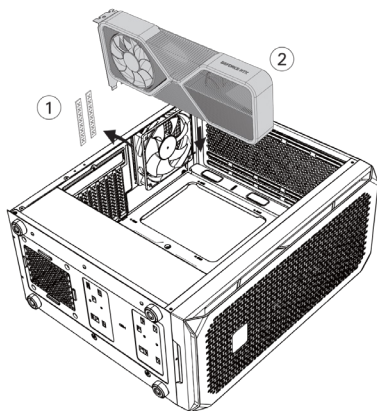

2) Motherboard installation

2) Instalación de la placa base

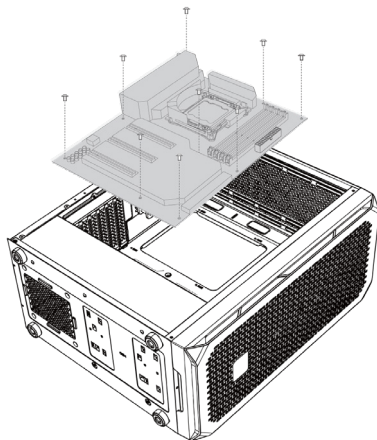

4) Power supply installation

4) Instalación de fuente de alimentación

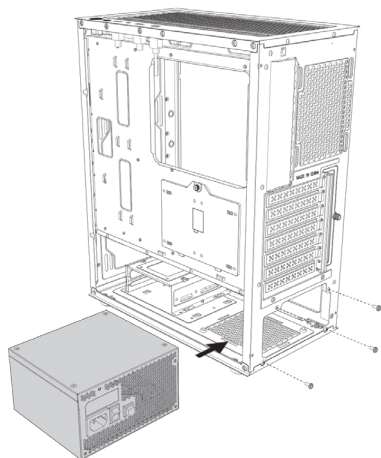

5) Hard disk installation

5) Instalación del disco duro

a) Installing a 3.5" hard disk drive

a) Instalación de un disco duro de 3,5"

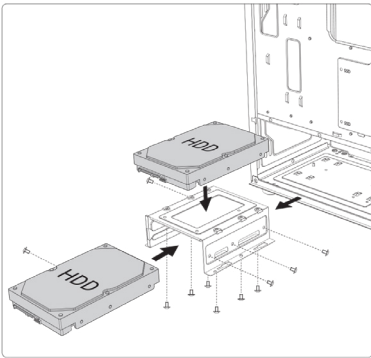

b) Installing a 2.5" solid state drive

b) Instalación SSD de 2,5"

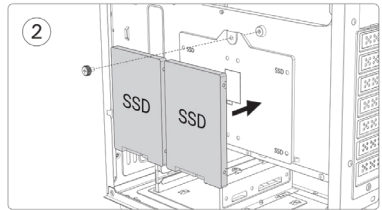
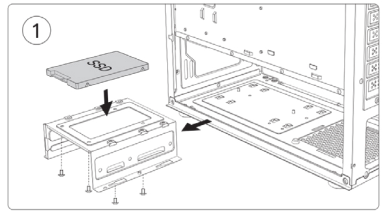

6) Fan installation

6) Instalación de ventiladores

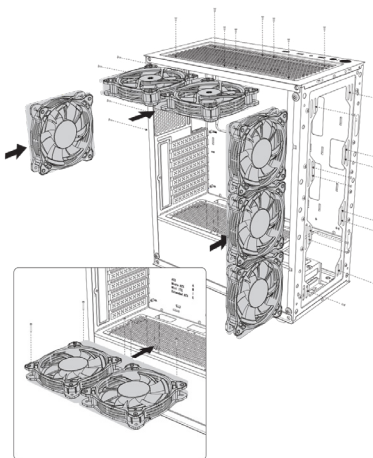

7) Installing liquid cooling radiator

7) Instalación de enfriamiento líquido

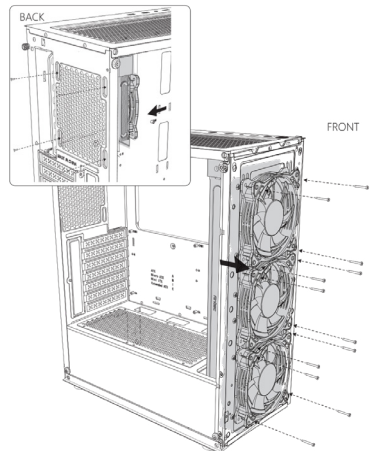

Specifications

Especificaciones

Model Modelo	GCM-ASGX1-01
Form Factor Factor de Forma	Mid Tower Media Torre
Overall Dimensions Dimensiones	15.3 x 7.8 x 17.7 in 390 x 200 x 450 mm
Motherboard compatibility Compatibilidad placa base	ATX, Micro ATX, Mini ITX
Max CPU cooler Altura máxima disipador CPU	6.1 in / 154 mm
Max VGA length Longitud máx tarjeta gráfica	13.5 in / 345 mm
Included fans Ventiladores incluidos	120 mm Black x 1
SSD Bay Ranuras SSD	2.5" SSD x 2
HDD Bay Ranuras HDD	3.5" HDD x 2
PSU Support Tipo de fuente de poder compatible	ATX
Expansion slots Bahías de expansión	7
Material Material	0.5 mm SPCC
Frontal Panel Panel frontal	USB 3.0 x 1 USB 2.0 x 2
Frontal Audio Audio Frontal	HD Audio Audio HD



Distributed by / Distribuido por:
Vadeto Group

USA
10065 Via de la Amistad A1,
San Diego, CA, US 92154
Tel. +1.(888).499.8103
www.getttech.us

MÉXICO
Calz. José Guadalupe Gallo #8490-A
Col. Agua Blanca Industrial, Zapopan, Jalisco, México
C.P. 45235 Tel. +52.33.1078.3404
www.getttech.com

ESPAÑA
CL Manuel Tovar N° 16,
28034 Madrid, España
Tel. +34.911.764.633
www.getttech.es